

Flasher & Hazard Circuit - Revised

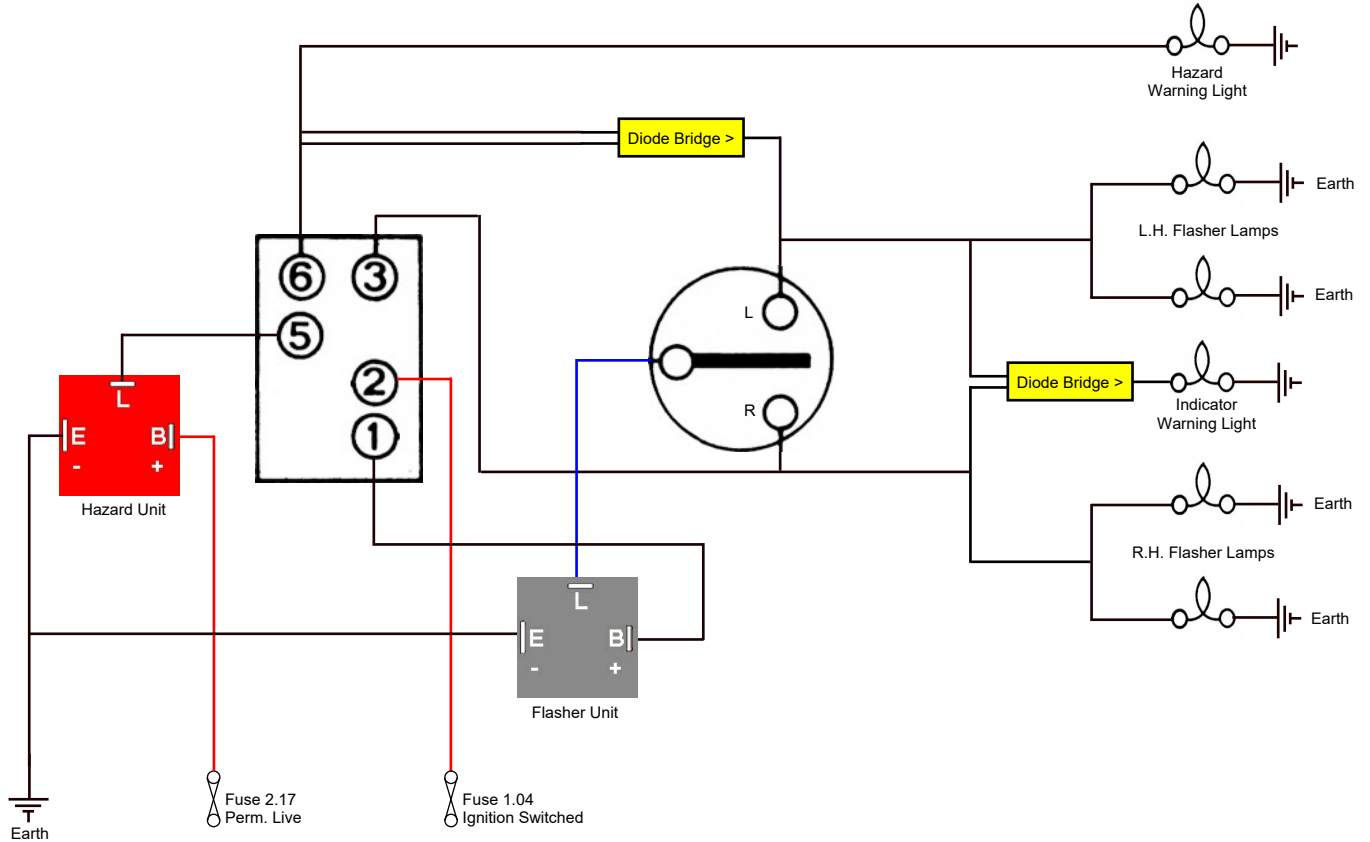

Hazard Switch Connections.

When the Hazard Switch is off, (1) and (2) are connected, allowing the Flasher circuit to complete,
 When the Hazard Switch is on (1) and (2) are disconnected. (5) is connected to (6 - LH Flashers and the Dash Lamp)
 and (3- RH Flashers).

CF14 JL-02 Relay Connections:

+/B = Live In; L = To Switch; -/E = Earth